

ABSOLUTE Digimatic Caliper

SERIES 500 — with Exclusive ABSOLUTE Encoder Technology

Mitutoyo's absolute Digimatic Caliper is the next generation of electronic calipers. It keeps track of its origin point once set. Whenever turned on, the large LCD screen displays the actual slider position ready to start measurement. No more repeated zero setting is necessary with the absolute encoder technology as well as no more care for overspeed errors.

High quality guide surface finish for smooth slider movement

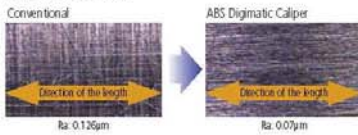

FEATURES

- Large and clear LCD readout.
- The ZERO/ABS key allows the display to be Zero-Set at any slider position along the scale for incremental comparison measurements. This switch will also allow return to the absolute (ABS) coordinate and display of the true position from the origin point (usually jaws-closed point).
- Data Hold Unit (959143) is optional.
- Carbide-tipped jaw type calipers are also available.



DIMENSION

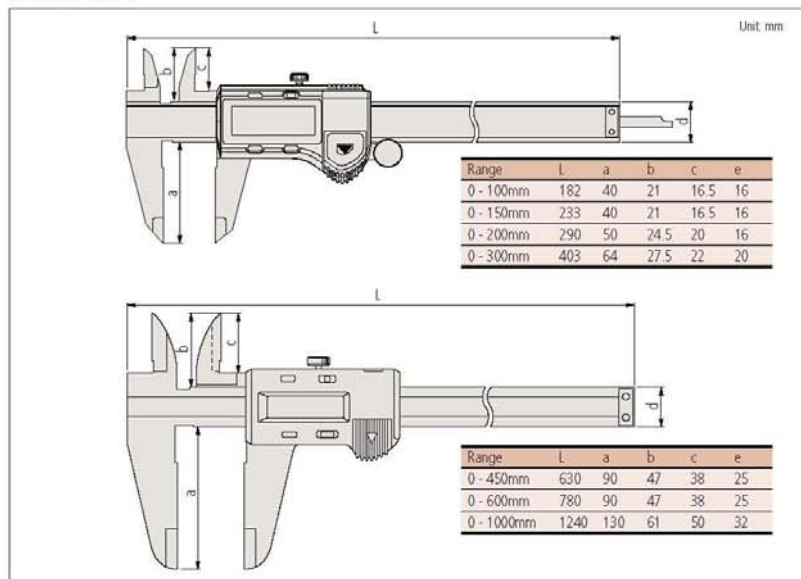

Absolute System Patented by MITUTOYO

(Refer to the page 9 for details.)



(Refer to the page 9 for details.)

Technical Data

Accuracy: $\pm 0.02\text{mm}$ ($\leq 200\text{mm}$), $\pm 0.03\text{mm}$ ($\leq 300\text{mm}$), $\pm 0.05\text{mm}$ ($\leq 600\text{mm}$), $\pm 0.07\text{mm}$ ($\leq 1000\text{mm}$) (excluding quantizing error)
 Resolution: 0.01mm or 0.005"/0.01mm
 Repeatability: 0.01mm
 Display: LCD
 Length standard: ABSOLUTE electrostatic capacitance type linear encoder
 Max. response speed: Unlimited
 Battery: SR44 (1 pc), **938882**
 Battery life: Approx. 3.5 years under normal use

Function

Origin-set, Zero-setting, Data output, inch/mm conversion (inch/mm models)
 Alarm: Low voltage, Counting value composition error

Optional Accessory

- 959143**: Data hold unit
- 959149**: SPC cable with data switch (1m)
- 959150**: SPC cable with data switch (2m)

959143



959149

SPECIFICATIONS

Metric					
Range	Order No.	Remarks (depth measuring bar / thumb roller / others)			
0 - 100mm	500-150-20	ø1.9mm rod	with thumb roller	—	
0 - 100mm	500-180-20*	ø1.9mm rod	—	—	
0 - 150mm	500-151-20	Blade	with thumb roller	—	
0 - 150mm	500-154-20	Blade	with thumb roller	—	Carbide-tipped jaws for OD measurement
0 - 150mm	500-155-20	Blade	with thumb roller	—	Carbide-tipped jaws for OD & ID measurement
0 - 150mm	500-158-20	ø1.9mm rod	with thumb roller	—	
0 - 150mm	500-181-20*	Blade	—	—	
0 - 200mm	500-152-20	Blade	with thumb roller	—	
0 - 200mm	500-156-20	Blade	with thumb roller	—	Carbide-tipped jaws for OD measurement
0 - 200mm	500-157-20	Blade	with thumb roller	—	Carbide-tipped jaws for OD & ID measurement
0 - 200mm	500-182-20*	Blade	—	—	
0 - 300mm	500-153	Blade	with thumb roller	—	
0 - 450mm	500-500-10	—	—	—	
0 - 600mm	500-501-10	—	—	—	
0 - 1000mm	500-502-10	—	—	—	

*without SPC data output

Inch/Metric					
Range	Order No.	Remarks (depth measuring bar / thumb roller / others)			
0 - 4"	500-170-20	ø3/40" rod	with thumb roller	—	
0 - 4"	500-195-20*	ø3/40" rod	with thumb roller	—	
0 - 6"	500-171-20	Blade	with thumb roller	—	
0 - 6"	500-174-20	Blade	with thumb roller	—	Carbide-tipped jaws for OD measurement
0 - 6"	500-175-20	Blade	with thumb roller	—	Carbide-tipped jaws for OD & ID measurement
0 - 6"	500-178-20	ø3/40" rod	with thumb roller	—	
0 - 6"	500-196-20*	Blade	with thumb roller	—	
0 - 6"	500-159-20*	Blade	with thumb roller	—	Carbide-tipped jaws for OD measurement
0 - 6"	500-160-20*	Blade	with thumb roller	—	Carbide-tipped jaws for OD & ID measurement
0 - 8"	500-172-20	Blade	with thumb roller	—	
0 - 8"	500-176-20	Blade	with thumb roller	—	Carbide-tipped jaws for OD measurement
0 - 8"	500-177-20	Blade	with thumb roller	—	Carbide-tipped jaws for OD & ID measurement
0 - 8"	500-197-20*	Blade	with thumb roller	—	
0 - 8"	500-163-20*	Blade	with thumb roller	—	Carbide-tipped jaws for OD measurement
0 - 8"	500-164-20*	Blade	with thumb roller	—	Carbide-tipped jaws for OD & ID measurement
0 - 12"	500-173	Blade	with thumb roller	—	
0 - 12"	500-167	Blade	with thumb roller	—	Carbide-tipped jaws for OD measurement
0 - 12"	500-168	Blade	with thumb roller	—	Carbide-tipped jaws for OD & ID measurement
0 - 12"	500-193*	Blade	with thumb roller	—	
0 - 12"	500-165*	Blade	—	—	Carbide-tipped jaws for OD measurement
0 - 12"	500-166*	Blade	—	—	Carbide-tipped jaws for OD & ID measurement
0 - 18"	500-505-10	—	with thumb roller	—	
0 - 24"	500-506-10	—	with thumb roller	—	
0 - 40"	500-507-10	—	with thumb roller	—	

*without SPC data output

